

4

3

2

1

| REVISIONS |     |             |      |          |
|-----------|-----|-------------|------|----------|
| ZONE      | REV | DESCRIPTION | DATE | APPROVED |
|           |     |             |      |          |

NOTES

- 1. DIMENSIONS IN INCHES
- 2. DO NOT SCALE DRAWING
- 3. DRAWING IS NOT FOR CONSTRUCTION
- 4. CONSULT FACTORY FOR CERTIFIED DIMENSIONS
- 5. SUCTION FLANGE: 10"/150# ANSI FF
- 6. DISCHARGE FLANGE: 10"/150# ANSI FF
- 7. APPROX. WEIGHT: 15,500 LBS

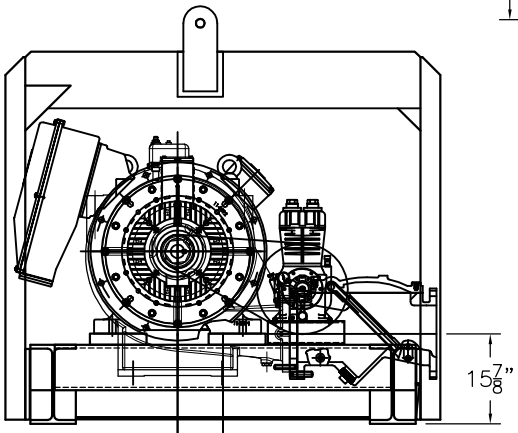
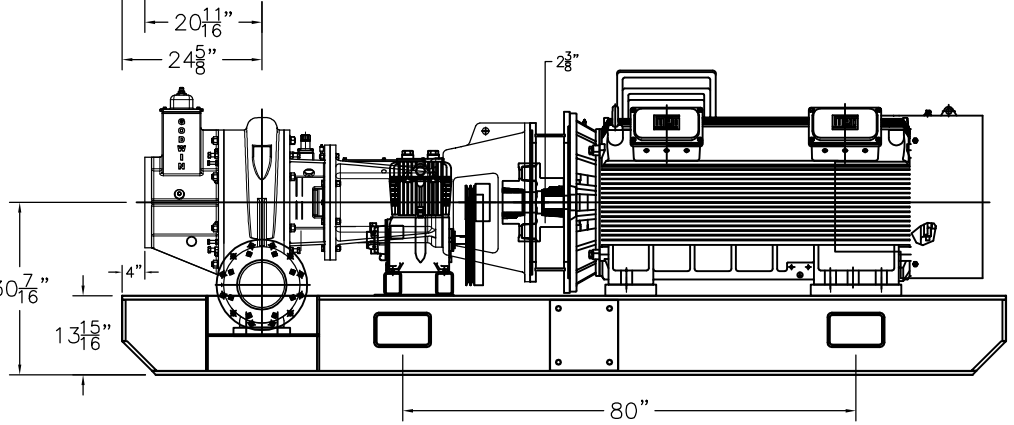
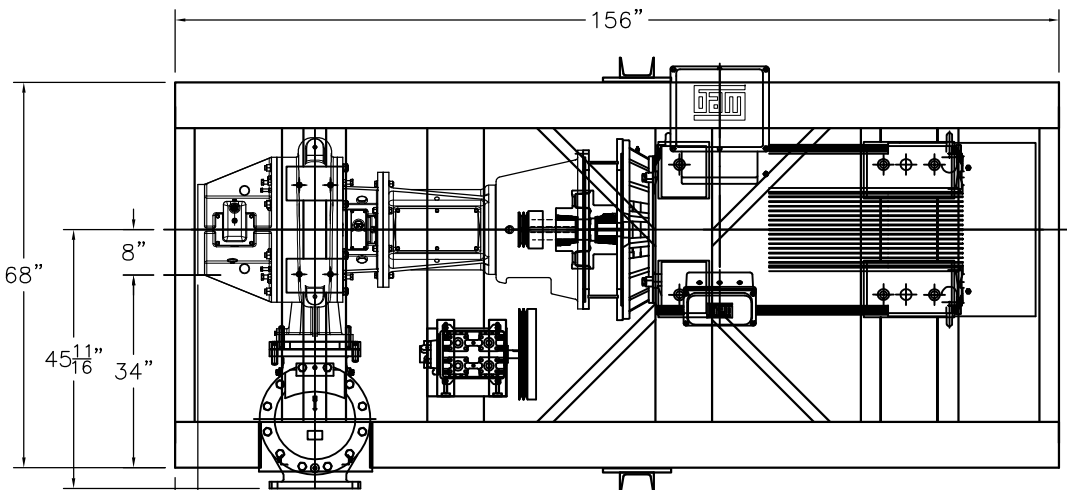

04 Floodgate Road, Bridgewater, NJ 08014, USA  
 (856) 487-3838 - Fax: (856) 487-5876

TITLE  
**HL260M**  
**600HP 1800RPM**  
**PORTABLE SKID**

CONTRACT# XXX  
 SIZE C DWG NO. 3376 REV 1  
 SCALE 1/1 SHEET 1 OF 1

SYMBOLS ETC. TO ANSI Y14

THIRD ANGLE PROJ.

UNLESS OTHERWISE SPECIFIED DIMENSIONS ARE IN INCHES AND INCLUDE COATINGS TOLERANCES ARE:  
 2-PLACE DECIMALS ± .03  
 3-PLACE DECIMALS ± .010  
 ANGLES FRACTIONS 1/16

| APPROVALS   |            | DAY | MON. | YEAR |
|-------------|------------|-----|------|------|
| DRAWN BY    | D. STETSER | 14  | 04   | 10   |
| APPROVED BY | X          | X   | X    | X    |
| ISSUED      | X          | X   | X    | X    |

REV. 1  
 DWG NO. 3376

4

3

2

1

A